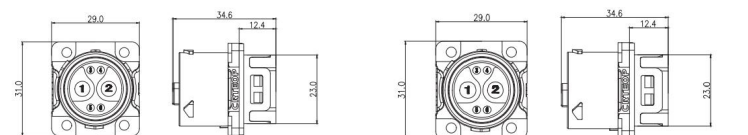
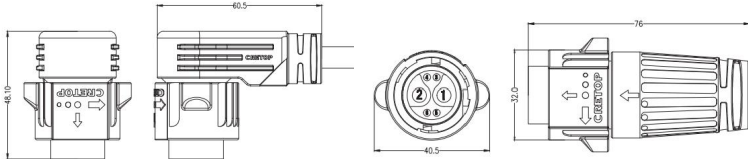
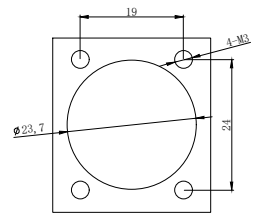

Mate60 2+4 充放电连接器 产品规格书

产品示意图Illustration	外形尺寸图Overall dimension (单位Unit: mm)
	
插座安装开孔图 Panel cut-out	
面板推荐厚度: ≤5mm Panel thickness	

技术参数Technical data

序号No.	类别Type	项目Item	参数Data
1	基本参数 Basic parameters	产品应用 Product application	为电动摩托车充放电提供电气连接 Provide electrical connection for discharging and charging of electric motorcycle
2		互配方式 Mating type	旋转自锁 Lock Structure
3		壳体 Shell	高强度热塑性树脂 High strength thermoplastic resin
4		密封件 Sealing	硅橡胶 Silicone Rubber
5		端子表面处理 Contact plating	镀金/镀银 Gold/Sliver plating
6		产品特征 Product Characteristics	采用三卡点PUSH LOCK结构, 操作手感更加顺畅 Three points push-lock locking mechanism, plug in & out easy and smoothly
7	电气特性 Electrical characteristics	额定电压Voltage rating	80V DC
8		额定电流Current rating	50A
9		阻燃等级Flammability Rating	UL94V-0
10		绝缘电阻Insulation resistance	>100MΩ
11		耐电压Withstanding voltage	1500V AC
12		端接方式 Wire processing	压接 Crimping
13	机械特性 Mechanical characteristics	插拔力 Mating and unmating force	插拔力<100N Mating force <100N
14		插拔寿命Durability	≥3000次cycles
15	环境特性 Environmental characteristics	盐雾测试Salt Spray	48h
16		温度范围Operation temperature	-40℃~105℃
17		防护等级Degree of protection	IP67
18		有害物质Harmful substances	RoHS 2.0

签字栏Signature section

版本 Version	文件编号 Document Number	编制部门 Set by	编制人 Created/Revised by	审核人 Audited by	批准人 Approved by
V1	KRD-GGS-20230513	研发部	孙君 2023.05.13	赵宏 2023.05.13	周洋军 2023.05.13